



City of Bremerton

PUBLIC WORKS

ENGINEERING DIVISION

TRAFFIC SIGNAL/STREETLIGHTING

SERVICE CABINET

Alteration of this drawing is prohibited. Any approval of an altered drawing is unauthorized and void.

7016

Revision Date
10-15-09

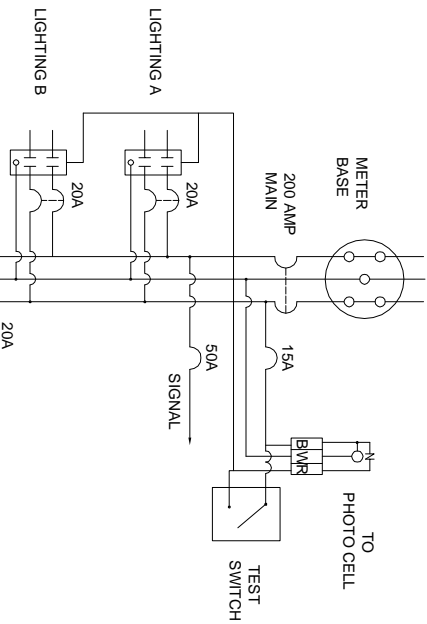

- NOTES:
- 50. C.H. 2P 200 AMP MAIN (BAB2100)
 - 51. C.H. 2P 20 AMP BREAKER (BAB2020)
 - 52. C.H. 1P 50 AMP BREAKER (BAB1050)
 - 53. C.H. 1P 20 AMP BREAKER (BAB1020)
 - 54. C.H. 1P 15 AMP BREAKER (BAB1015)
 - 55. METER ENCLOSURE (124TB MILBANK)
 - 56. HUBBELL SWITCH (CS1201-I)
 - 57. GFCL RECEPACLE 20 AMP (LEVITON 6898-I)
 - 58. SQ. D #8910PPA32V02U1
 - 61. SOUTHCO DOOR S.S. HINGE (F6-3-1)
 - 64. STAINLESS STEEL HANDLE
 - 65. DEAD BOLT LOCK "BEST" (SL7RL2-626)
 - 66. SQUARE D TERMINAL BLOCK
 - 67. SQUARE D END CAP
 - 70. 1"X.25" GASKET

BREAKER SCHEDULE										
SERVICE VOLTAGE: 120/240		BUS RATING: 200 AMP		LOCATION		DRAWING #				
MOUNTING:		BUS CONNECTION: 2-P 3-W		MAN-BREAKER: 100 AMP		BRANCH: 13		LINE AMPS: 300 AMP		
CIRCUIT DESCRIPTION	VOLTS	AMP	BREAKER	POLE NO.	CONNECTION	NO.	BREAKER AMP	POLE	VOLTS	CIRCUIT DESCRIPTION
MAIN	A	200	2	1	A	2	15	1	1440	4800
LIGHTING A	B	200	2	3	B	4	50	1	1920	SIGNAL
LIGHTING B	A	200	2	5	A	6	20	1	1920	RECEPTICAL
TOTAL		3940							3980	4800

COMMENTS: 124TB MILBANK METER SOCKET

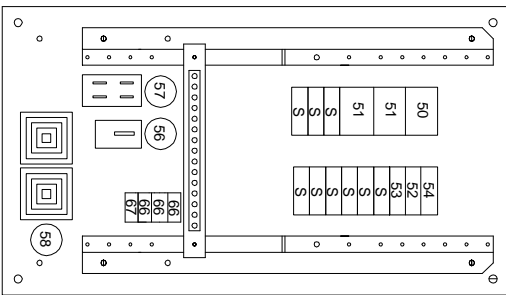

RATED NEMA 3R
LISTED 508 UL
CONTRACTOR IS RESPONSIBLE TO
VERIFY METER AMPERAGE
ARRANGEMENT



1820 BICKFORD AVE. SNOHOMISH WA
(360)568-0572 Fax (360)568-0577

MATERIAL: .125 5052-H32 AL	THIS DRAWING IS THE PROPERTY OF BROWNFIELD MANUFACTURING, INC. AND ITS SUBMISSION DOES NOT GRANT THE RIGHT TO MAKE USE OR SELL WHAT IS REPRESENTED HERE IN WITHOUT THE PRIOR WRITTEN CONSENT OF BROWNFIELD MANUFACTURING INC.
COATING TYPE:	SCALE = NONE
DRAWN BY: WYKE MCCOY/AD	WORKING DRAWINGS BUILD TO THESE SPECIFICATIONS
HARDWARE:	DATE: 03/07/03
FINISH: POWDER COAT ASA-61 GREY	PAGE: 1 OF: 1
COLOR:	
DATE: 03/07/03	